

Franklin's Anderson
Salt Lake City Office

2/84

Re: Radar Case Study

Uses for the Microwave Spectrum

Stanford Park Division

Manic Nardorzi 5/84

USES FOR THE MICROWAVE SPECTRUM

- **COMMUNICATION**
terrestrial
satellite
- **RADAR**
surveillance
tracking
guidance
range instrumentation
weather, scientific
- **NAVIGATION**
enroute position systems
landing systems
- **ELECTRONIC WARFARE**
intelligence gathering
countermeasures
- **OTHER**
MW ovens and industrial heating
particle accelerators
radio astronomy
telemetry
antenna test ranges

Uses for the Microwave Spectrum

There are four major sectors of microwave applications; communications, radar, navigation and electronic warfare. In addition, there are a number of other interesting applications in a miscellaneous category.

A variety of communications equipment operates at microwave frequencies. Best known are the fixed line-of-sight communication systems (as operated by the telephone companies). Satellite systems are the newest and fastest-growing segment.

Radar systems also operate in this part of the spectrum because directional antennas are easier to achieve at higher frequencies. These systems are used either for surveillance (as in the ground based radars that scan the horizon for airplanes), as tracking radars designed to acquire and then follow an object (airplane or missile), and finally radars intended for missile guidance applications. Here the radar is used not only to follow the target, but to control the flight of the missile to intercept the target. Sometimes the missile itself has its own guidance radar.

The third major application for the microwave spectrum is in navigation systems. These fall into two major categories; one category used to keep track of the position of airplanes en-route between cities. Systems here include VHF omni-range and the recently-announced Global Positioning System. The second class of navigation systems has to do with the ground controlled approach to an airfield; systems that allow the pilot to fly the last few miles (in some cases, right to touch-down on the runway), under electronic guidance.

The last use of the microwave spectrum is called electronic warfare (EW). This application relates to the use of the spectrum in military activities or by military systems. It is divided into two subcategories; one that deals with gathering intelligence about the systems being used by potential enemies. For example, the U.S. has surveillance airplanes that are designed to measure the characteristics of the radar signals from non-friendly ground based radars that are either used for surveillance or for tracking and guidance. The other electronic warfare technique is called electronic counter measures (ECM). These are electronic systems that are expressly designed to confuse the enemies' offensive weapon systems that are electronically based. For example, a pilot will often attempt to nullify missiles that are designed to destroy his airplane by transmitting a signal from a jammer that confuses the missile's radar system.

So there are the four primary areas of use for the microwave spectrum. The purpose of our lecture today is to look at each in some detail so that you have an understanding of what your customer is doing when he talks about the communication, radar or electronic warfare system he wants to test.

If we have time, we'll also mention other uses such as microwave ovens and industrial heating applications. Particle accelerators and radio astronomy have important scientific applications as do molecular and atomic resonance studies. Microwave telemetry has major uses in the aerospace sector.

FREQUENCY NOMENCLATURE

RF SPECTRUM

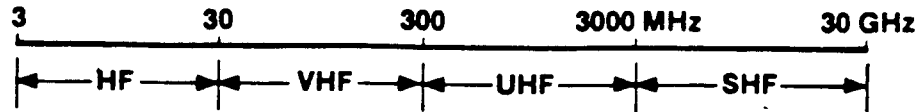

MICROWAVE SPECTRUM (mostly coax)

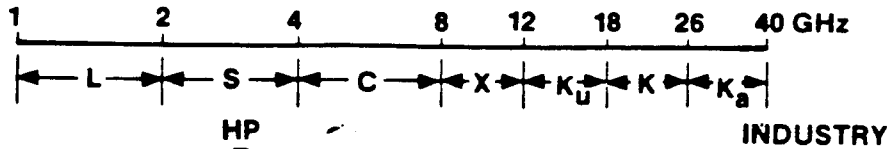

HP and INDUSTRY WAVEGUIDE DESIGNATIONS

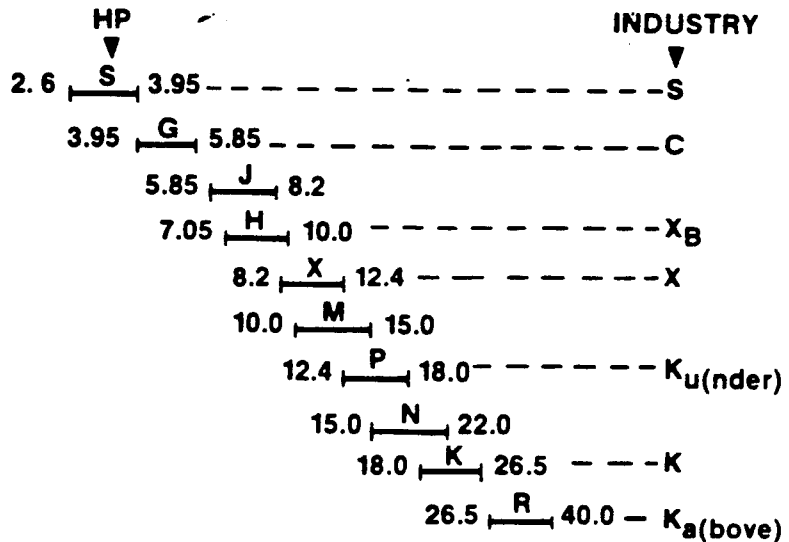

ELECTRONIC WARFARE BANDS

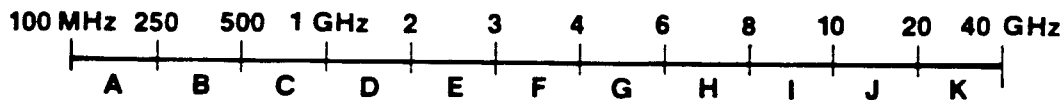

The term *microwaves* is commonly understood to range from about 300 MHz (1 meter wavelength) to above 300 GHz (1 mm wavelength). By far most activity is below 18 GHz with some emerging communication, radar, and EW usage going to 40 GHz and a little radar work to 100 GHz and beyond.

Most applications from 1000 MHz up use wideband modulations, typically pulsed, wideband FM, or other spread spectrum phase modulations. This is in distinction to narrow band mobile FM with 25 kHz channel spacing. A radar pulse with 1 μ s pulse width will require 10 to 20 MHz receiver bandwidth to pass most of the wideband spectrum. A frequency domain multiplex channel for microwave communication uses 20–35 MHz bandwidth.

1–18 GHz is ideal for radar and communications. The air, clouds and haze which obscure optical beams are transparent to these frequencies. Certain transmission “holes” are also present at around 26 and 36 GHz.

For convenience, the microwave spectrum has been subdivided into bands. Engineers commonly refer to a system by its band rather than its specific frequency of operation. A C-band communication system, for example, may operate at a frequency between 3.7–4.2 GHz; the actual frequency of operation depends on local licensing and compatibility considerations.

Note that HP waveguide instruments and accessories carry a band designation and these do not necessarily correspond to the industrial convention.

MICROWAVE COMMUNICATIONS

SERVICE	BANDS	APPLICATION	USERS
Terrestrial	L, C, X	Voice	Common Carriers
		Data/Fascimile	Telephone Companies Business-Transportation Pipelines Railroads
		TV	Remote Pick-Up Studio-Transmitter Links CATV Head End Network Programming
		All	Government & Military Remote Radar-FAA Battlefield Links Troposcatter RPV Command Link Secure — (JTIDS, SEEKBUS)
Satellite	C, X, K	Voice	Common Carriers
		Data/Fascimile	Telephone Companies Western Union COMSAT/INTELSAT Business
		TV	SBS-IBM, Aetna, COMSAT CATV Distribution Direct Broadcast Satellite Network Programming
		All	Government & Military Command, Control Communications (DSCS) Maritime (MARISAT) Surveillance

This slide summarizes MW communications systems. One type is called a terrestrial MW system and operates in L, C and X-bands. These systems can be fixed or mobile and can carry hundreds of voice channels as we'll see in a minute. They also carry data between computers, or facsimile information as in wire photos, and finally in network broadcasting applications to send TV pictures from one area to another. The telephone company is the principle user of terrestrial MW systems, although lately independent businesses have installed their own private systems. Oil and gas companies, for example, use terrestrial MW systems to control the valves and pumping stations along an oil distribution or natural gas pipeline. CATV operators will also use terrestrial MW systems to feed a signal from a mountaintop antenna to the head end of a cable distribution system in the city. And, of course, the Federal Government operates large numbers of terrestrial MW systems, especially for military use.

The second type is called a satellite system, typically at 4 and 6 GHz and 11 and 14 GHz. You often hear these frequencies mentioned as pairs because the communication from an earth station to the satellite is at one frequency (UPLINK) (usually the higher of the two frequencies since it's easier to generate high carrier power on the ground). The communication from the satellite back to another earth station is done at the second (lower frequency) (DOWNLINK). The information that is being transmitted is the same as that of a terrestrial MW system. The choice between terrestrial and satellite systems depends on how far the information has to go, not what's being transmitted. Satellite is preferred for long haul. The users of the spectrum are generally the same as in terrestrial MW case except the CATV people, who generally speaking, are not users of satellite systems, but the TV networks themselves are.

MICROWAVE COMMUNICATIONS TYPICAL TERRESTRIAL SYSTEM

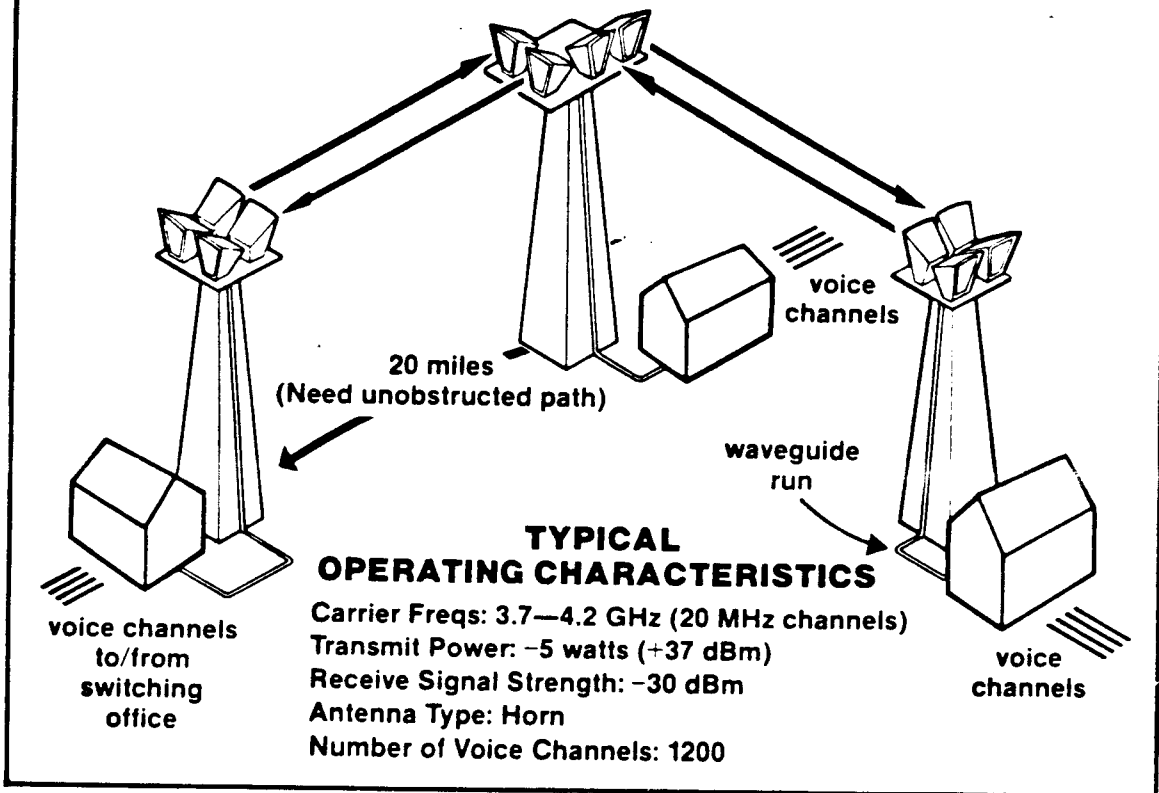

This shows in diagram form the typical terrestrial MW system. The electronics is housed in a small building with a waveguide run to a tower that gets the transmit and receive antennas approximately 100 feet off the ground. That's necessary to have an unobstructed view of the tower to which you are transmitting. A typical transmitter would operate in a band (e.g., 3.7 to 4.2 GHz) on one of the twelve channels available (20 MHz spacing). The transmitter would put out about 5 watts, given the normal path loss for a 20 mile hop and normal antenna gains. The antennas are end-fed horns, one transmit, one receive for each direction. These terrestrial MW systems operate with the same station pairs at all times. They are not intended to be switched around.

As we said earlier, with a MW communication system, the bandwidth of the information is generally much wider than a single voice channel. A typical system will operate with 1,200 voice signals simultaneously. We will see how this is accomplished in a minute.

Many FAA air route surveillance radar antennas are placed on high mountains for obvious reasons. To prevent air control crews from having to work on that site, the display video is transmitted to the route control centers for computerized processing and human overview. Other systems are mobile, especially military.

A specialized case of communications is the command, control and communication link with remote piloted vehicles. More will be said under electronic warfare applications. Such links must be highly secure and as impervious to jamming as possible. Typically, the links at 10 GHz are quadrature phase-shift-keyed modulated with pseudo-noise codes and may be frequency hopped at the same time. Such techniques are termed spread spectrum.

SEEKBUS is a high security communication system linking the airborne early warning and control airplane (AWACS) to headquarters using L-band (1230 MHz). JTIDS is a highly sophisticated digital network tying together entire sea and air groups.

MICROWAVE COMMUNICATIONS TYPICAL SATELLITE SYSTEM

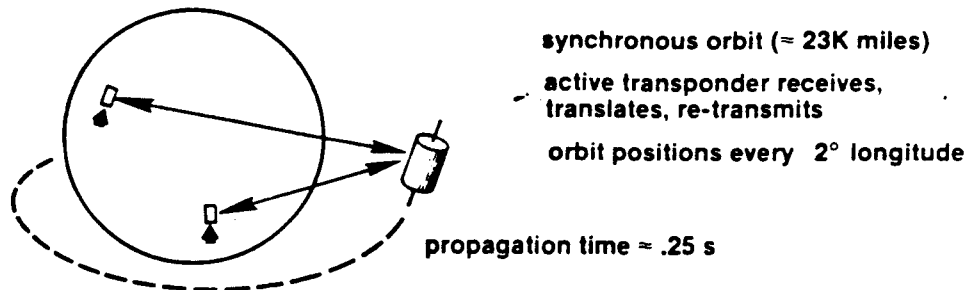

TYPICAL OPERATING CHARACTERISTICS

Carrier Freqs: 6 GHz \uparrow /4 GHz \downarrow ; 14 GHz \uparrow /11 GHz \downarrow

Transmit Power: \approx 10 kW (+70 dBm) \downarrow

\approx 10 W (+40 dBm) \uparrow

Receive Signal Strength: -40 dBm \uparrow

-70 dBm \downarrow

Antenna Type: parabolic dish (30 meter)

Satellite Life Cost: 7 years, \$50M

Earth Station Cost: \$5M

With satellite communications, earth stations aim their antenna at a satellite that's usually in synchronous equatorial orbit, 22,500 miles above the earth's surface. The satellite is a transponder. It responds to an uplink signal from the ground, shifts its frequency and retransmits back to the ground, sometimes with spot antennas and sometimes with hemispherical coverage. Equatorial orbit will soon be a crowded piece of space. Given current antenna patterns, orbit positions are available about every 2 degrees longitude, and it's filling up over the Atlantic. You can recognize when your long distance telephone conversation is being handled by satellite because of the inherent delay in the 50,000 mile round trip to and from a satellite. That corresponds to a propagation delay of about one-fourth second and results in a noticeable lag in the conversation as you finish, but before your partner's voice reaches you.

A typical system would operate with, say, a 6 GHz uplink and a 4 GHz downlink, or now that orbit positions are filling, with a 14 GHz uplink and an 11 GHz downlink. The earth station transmits a fair amount of power, typically 10 kW. The satellite transponds at about a 10 watt level. As a result, the receive signal at the satellite is much stronger than at the ground station, but of course the ground station can have a very large antenna. The antennas are parabolic dishes and in most systems they are quite large to provide the best possible signal-to-noise ratio given the limited amount of transmit power available in the satellite. The satellite itself has an intended life of 7 years and a cost (electronics plus the launch vehicle) of about \$50M. A high quality earth station approaches \$5M, but several low performance models are now available for as little as \$100K, and Heath Kit and Scientific Atlanta are talking about \$10—15K.

SATELLITE COMMUNICATIONS

There are a variety of other common carrier and non-US government satellite systems in place and planned. You'll see names like DOMSAT, ALASCOM, ARABCOM, Indonesian and Japanese systems.

Probably one of the most exciting satellite areas to emerge recently is the announcement of the Satellite Business Systems Company formed by IBM, Aetna Insurance, and COMSAT Corp. to deploy a time division multiple access system. The concept is light to moderate traffic from 10 to 15 thousand ground stations. Thus, a decentralized company like HP could put a 5 meter dish on the rooftops of each sales office or division and with digital modulations on 14 and 11 GHz signals communicate with any other address. Time slot allocations come from a master system controller, and traffic can be data, voice, facsimile, or even tele-conferencing. With the principle backers names as shown, you can count on a successful venture.

The technology of broadcasting video directly to widely dispersed ground stations for educational programs or CATV program relay has already been demonstrated. Medical and health training for eskimo villages is one application. CATV companies also see this as one way to get clean front-end signals to put into their cable distribution. Direct commercial broadcast for home TV is coming on fast, too. It will be in K_u band.

There is a rapidly growing technology of military command and control systems involving satellites. Most of these use digitally phase modulated signal formats with cryptographically secure coding and various means to make them impervious to jamming by using spread spectrums.

A tactical system is FLEETSATCOM which actually uses VHF bands and will be able to establish 2 way links with ship or even jeep-mounted small dishes. A more strategic level is the highly sophisticated Defense Satellite Communications System (DSCS) operating in H-band, 7.1 to 8.4 GHz which will have capabilities of very wide band channels to permit heavy traffic and too resistance to jamming.

A variety of other systems proliferate. MARISAT is a combined commercial/government system for communicating with ships at sea. Oil tankers will save hundreds of thousands of dollars by being able to communicate docking schedules and routing information.

Some classified systems also use satellites for information transfer. Another system uses satellites to receive ocean and weather data from hundreds of ground recorders as the bird passes overhead. Later when it passes the ground control center it passes the accumulated world data back on a wideband link.

COMMUNICATIONS FREQUENCY ALLOCATIONS – USA

Band Name	Common Carrier	Business/ Transportation	TV/Community Antenna Relay Systems	Federal Government
2 GHz	1.71—1.85	1.85—1.99	1.99—2.11	1.71—1.85
	2.11—2.13			
	2.16—2.18	2.13—2.15	2.15—2.16	
		2.18—2.20		
		2.45—2.50		2.20—2.29
4 GHz	3.7—4.2 ▼			4.4—5.0
6 GHz	5.925—6.425 ▲	6.575—6.875	6.875—7.125	
7 GHz				7.125—8.4 ▼
11 GHz	10.7—11.7 ▼ 11.7—12.2	12.2—12.7	12.7—12.95 12.7—13.25	14.4—15.25
14 GHz	14.0—14.5 ▲			
18 GHz	17.7—23.6 ▼	22		
30 GHz	27.5—31.0 ▲	39		
	40—41 ▼ 50—51 ▲			
▲ Satellite Uplink ▼ Satellite Downlink				

Frequency allocations in the USA are the responsibility of the Federal Communications Commission. Internationally the International Telecommunications Union (ITU) coordinates national allocations and any disputes arising.

Many terrestrial allocations also are used in up-down channels for satellite links. Specific licenses are only granted after careful study of other conflicting station assignments considering point directions, backscatter, etc.

MICROWAVE COMMUNICATION

MODULATION FORMATS

(multiple channel per carrier)

Frequency Division Multiplex

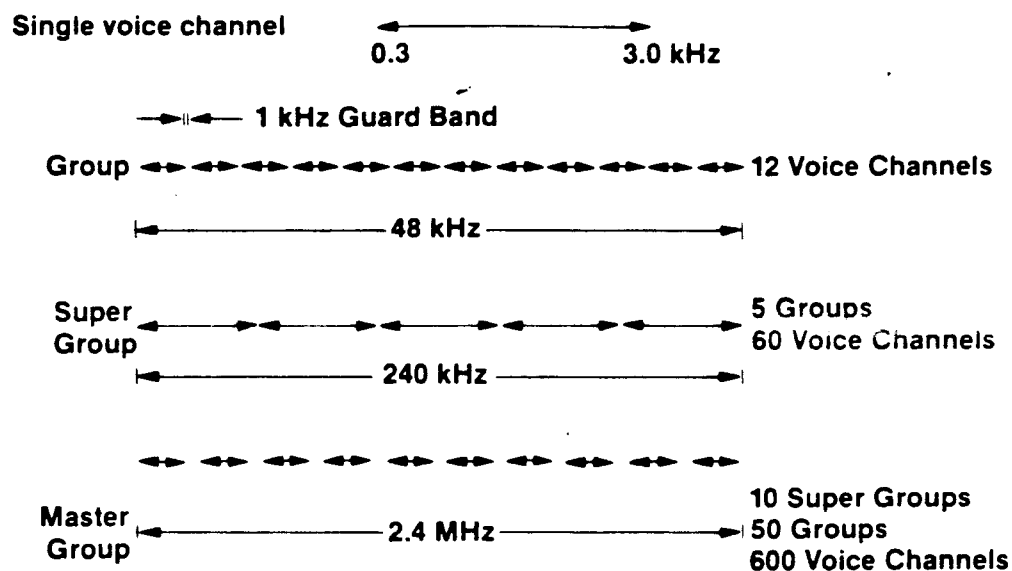

FDM Systems commonly handle 1200 or 1800 voice channels, (2 or 3 master groups) so baseband is ~ 6 or ~ 9 MHz wide.

We mentioned earlier that a MW communication system has several voice channels per carrier. This is achieved via Frequency Division Multiplexing. If a single voice channel has a spectrum from 300 Hz to 3 kHz, we can take 12 of these voice channels and mix each of them against a local oscillator to offset their frequencies so that they stack end to end and form a group that's 48 kHz wide. To make up the group we must filter the local oscillator and the unwanted sideband from each voice channel. Next we can take up to 5 of these groups, and by heterodyning and filtering, stack them end to end and wind up with a super group that has 60 voice channels and occupies 240 kHz. And again, take a super group and heterodyne it together with 9 other super groups to form a master group that's 2.4 MHz wide and contains 600 voice channels.

This is called Frequency Division Multiplex and the composite spectrum is referred to as the baseband that modulates the MW transmitter. For high density routes it's common to have systems that operate with two or three master groups and carry upwards of 1,800 voice channels, resulting in a total baseband that is almost 9 MHz wide.

"Light-route" links of 12 or 24 voice channels often use the 2 GHz band and some older links are at 900 MHz. These are narrower band channels useful for feeder routes in sparsely populated countries.

TYPICAL FDM TRANSMITTER

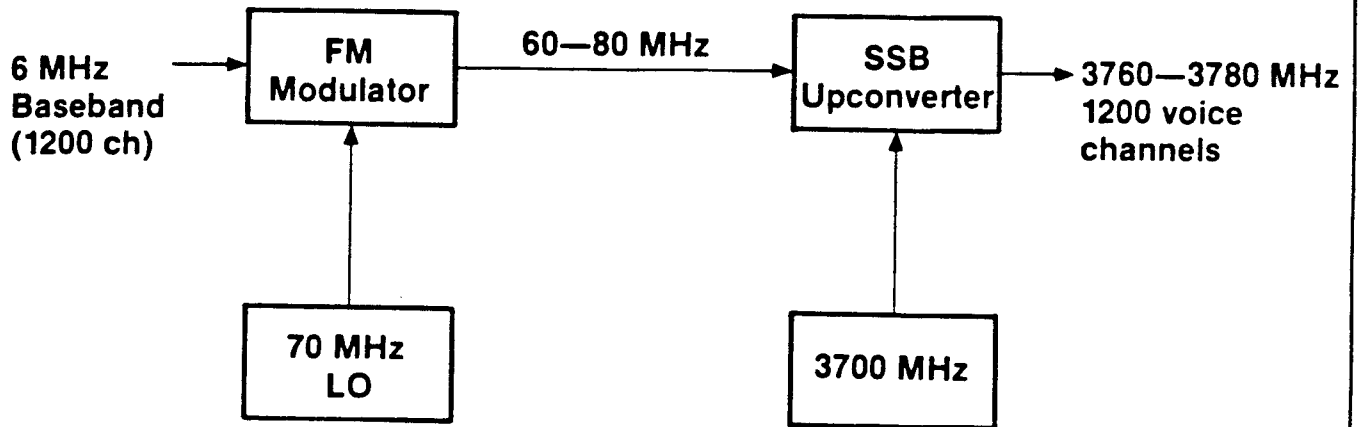

TD-3 long-haul system

This block diagram shows how the transmitter takes the composite baseband and uses that to frequency modulate a 70 MHz local oscillator. It then mixes that modulated 70 MHz against a MW oscillator to up-convert the FM spectrum to the C-band transmit frequency (in this case, 3770 MHz).

Video modulations easily fit into microwave carriers and satisfy applications of studio links and CARS systems. TV stations also use microwave for sports pick-ups and evening news minicam remote pick-up.

MICROWAVE COMMUNICATION MODULATION FORMATS

Time Division Multiplex

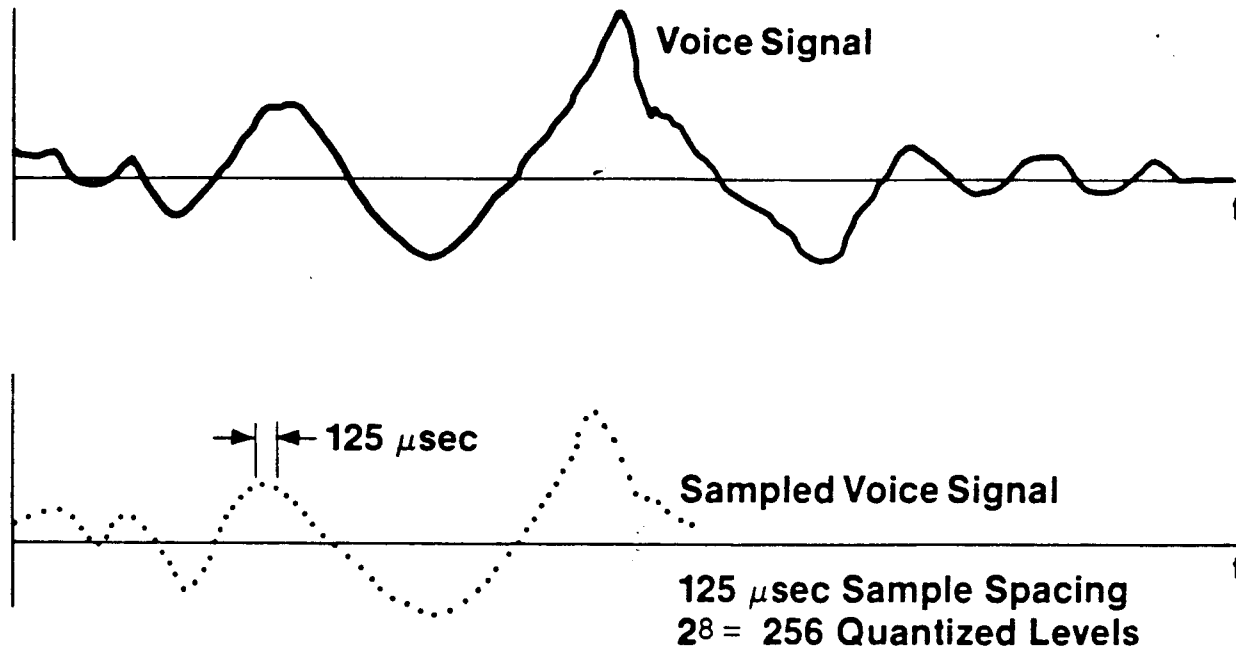

Each Voice Channel = 8000 samples/sec x 8 bits/sample
= 64 kbits/sec

24 Channels Interleaved = 1.536 Mbits/sec

Add "Housekeeping" = 1.544 Mbits/sec

Bell System T1

A second form of modulation that's becoming increasingly popular for MW communication systems is called Time Division Multiplex. Here instead of hetrodyning the spectrum of a single voice channel, the spectrum is digitized and transmitted as a string of 1's and 0's interleaved with similar strings for other voice channels. Instead of dividing the frequency spectrum, this method shares time.

Typical systems sample the voice signal every 125 μ s (this is the equivalent of a sampling frequency of 8 kHz) which is adequate to reproduce the voice spectrum since its highest frequency is generally 3 kHz or less. The digitization process involves an A to D converter typically with 8 bits of resolution. Eight bits means there are 2^8 or 256 possible digital outputs that represent the analog signal sample. Since each channel is being sampled 8,000 times a second and each sample contains 8 binary digits, the overall data rate per voice channel is 64,000 bits per second. If 24 channels are interleaved, the data rate becomes 1.536 megabits per second.

Additional information, called housekeeping, adds a few more bits per second to allow the decoding equipment at the receiving end to separate the channels and results in an overall transmission rate of 1.544 megabits per second (Bell Systems' T1).

DIGITAL HIERARCHY

BELL SYSTEM

T1	1.544 MBit/s (24 channels)
T2	6.312 Mbit/s (96 channels)
T3	44.736 MBit/s (672 channels)
T4	274.176 MBit/s (4032 channels)

EUROPEAN (CEPT)

2.048 MBits (30 channels)
8.448 MBit/s (120 channels)
34.368 MBits/s (480 channels)
139.264 MBit/s (1920 channels)

AT&T has 3 additional higher data rate formats for Time Division Multiplexing. In Europe, the standards are different. Japan also differs slightly from the AT&T or North American standard.

TYPICAL TDM TRANSMITTER

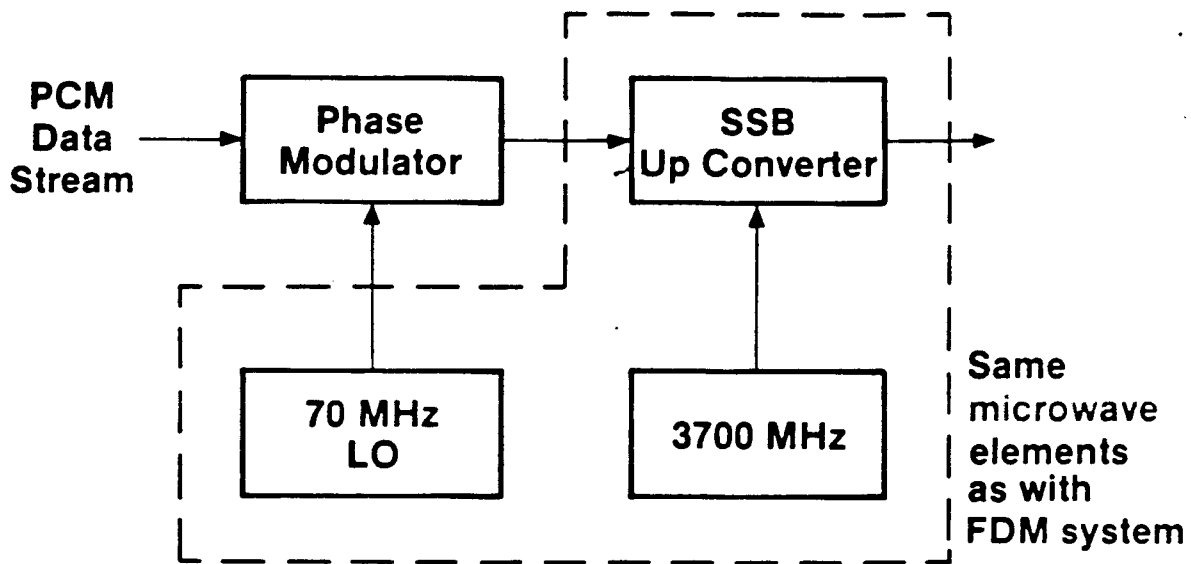

Phase Shift Keyed (PSK)

- 2 PSK Each state represents 0 or 1
- 4 PSK Each state represents 00, 01, 10, 11 (2 bits)
- 8 PSK Each state represents 000, 001, ... or 111 (3 bits)

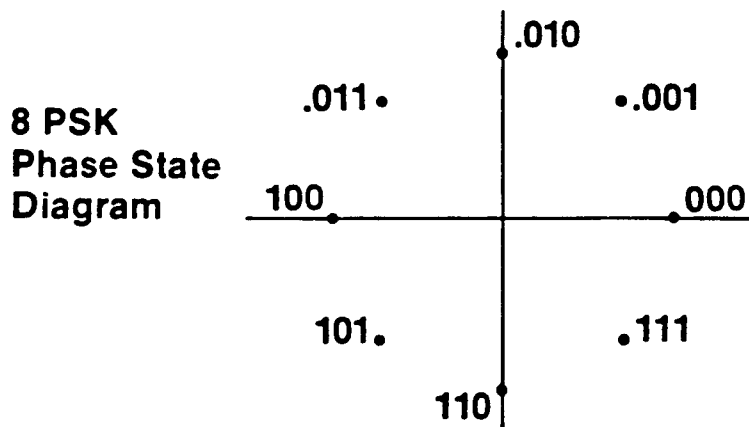

A typical transmitter for a Time Division Multiplex system uses the same RF elements that we saw earlier for the Frequency Division Multiplex system, but phase modulates the 70 MHz local oscillator. The data stream from the digitized 24 voice channels changes the phase between 2, 4 or 8 states. The polar diagram shows the phase states on an 8 PSK system where each state represents 3 bits in the data stream.

MICROWAVE COMMUNICATIONS

Measurement Considerations

- **FREQUENCY DIVISION MULTIPLEX**
Selective level measuring set (SLMS)
Intermodulations, noise loading tests
Pilot tones, frequencies
- **MICROWAVE CHANNELS**
Phase linearity and intermodulation effects,
much more critical than sensitivity, BW, NF
Microwave link analyzer (MLA)
Most tests at 70 MHz
Power output and frequency tests at microwave
Some swept amplitude tests on RF
Satellite testing much the same
- **TIME DIVISION MULTIPLEX**
Digital bit-error rate analyzers (BER)
Pulse and word generators
Much of microwave portions tested with MLA
Phase-shift-keyed modulations, BPSK, QPSK, CPSK

Multiplex communications testing is a well developed technology. The multi-channel signals use wave analyzers (SLMS) to do channel-by-channel tests or pilot tone measurements. Noise loading tests simulate an entire group or super group of channels loaded with traffic by notching out the noise in the test channel. The resulting intermodulation of all other noise-loaded channels into the clear channel shows how linearity is doing through all the amplifiers, mixers, and filters of repeater channel banks.

At the microwave level the Microwave Link Analyzer (MLA) is indispensable (it really works at IF of 70 or 140 MHz). The microwave test signal is swept through the microwave channel, then down-converted to 70 MHz and measured by the MLA. Special techniques give an extremely magnified display of phase linearity or delay. Even in the Bell Telephone TD-3 system with 150 hops across the USA, the MLA can nicely measure each segment to adequate resolution.

Microwave frequencies are measured with counters, and TWT output tubes running at above 1—5 watts with power meters. Sometimes channel loading is monitored on a spectrum analyzer.

Satellite ground stations and the bird itself require more sophistication and speed. Path losses are far greater, sensitivities are higher and output powers are much higher, although linearities are easier because there is only one "hop."

Time domain multiplex is emerging as an important new technology. Much of the MW "front end" testing is still done with an analog test equipment (MLA). Signal traffic is tested with bit-error rate testers. Signal generators like the 8663A with phase modulation can be configured to produce bi-phase-shift-keyed (BPSK) and quadra-phase-shift-keyed (QWPSK) modulated signals.

TYPE	APPLICATION	TYPICAL SYSTEMS	
		COMMERCIAL	GOVT/MILITARY
Surveillance	Air traffic control	Airport surveillance (TPS-48) Radar (ASR)	
		Secondary surveillance Radar (SSR)	
		Air route surveillance (ARSR)	Airport surface detection equipment (ASDE)
	Defense/early warning		Airborne warning & control (AWACS) Long range coastal (PAVE PAWS) Sea search (SPS-48) Satellite tracker (FPS-85)
	Battlefield tactical		Personnel/tanks (PPS-5)
Tracking	Fire control		Hawk (surface to air) F-14 (AWG-9) (air to air) AAA tank gun
	Multi-function Fire control Mapping/NAV Terrain following Weather		F-15 (APS-69)
	Police Mortar finding	Speed gun	Mortar detection radar
Guidance	Missile		Phoenix (F-14) Cruise missile Standard ARM
Range Instrumentation			Bomb scoring Test range radars
Weather	Severe weather warning	NOAA	
Scientific	Radio Astronomy	Green Bank, WV	
Radar altimeters		Commercial aircraft	same

Now let's take a look at the various kinds of radar systems that also use the microwave spectrum. As we said earlier, they divide into 3 main subcategories plus several others: *surveillance* radars used in air traffic control, defense early warning systems, or by the police department in speed traps; *tracking* radars used to aim weapons, especially weapons that are carried on airplanes such as the F-14 AWG-9 system for air-to-air missiles; and *guidance* systems that are often carried in the missile itself and are used for closing the final distance to the target. In the miscellaneous category are a wide variety of *test range*, *weather*, and *scientific* applications.

SURVEILLANCE RADAR

The Airport Surveillance Radar (ASR) is the one you will most likely see at all major airports. It operates between 2700 and 2900 MHz and is used to control aircraft within 30—40 miles of an airport. Since the ASR beam is good for range but not height of target, a Secondary Surveillance Radar (SSR) antenna is mounted on top of the ASR antenna.

By triggering an Air Traffic Control (ATC) Transponder inside the airplane, the SSR ground equipment receives a reply from the plane which includes encoded information of the flight number and altitude so that computer processing displays can present accurate traffic information. The SSR system operates at 1030 and 1090 MHz.

Air Route Surveillance Radars (ARSR) are large, long range systems operating at 1300-1350 MHz with 240 nautical mile range which monitor the domestic air route traffic.

Airport Surface Detection Equipment (ASDE) are often called "taxi radars" for controlling ground movement to prevent runway obstructions and ground accidents. You'll find them mostly in very dense airports such as Chicago and will recognize them by the fast rotation (1-2 per second) and by a relatively small antenna (5—10 feet). Operating frequency is 24—26 GHz to get resolution capable of detecting vehicles or even people.

Military search and acquisition radars are high-power long range systems. They naturally occur as ground-based, sea search, and the new AWACS look-down flying search radar. Most of these systems operate in L-band and S-band for reasons of high power but are fairly conventional design.

The AWACS system uses some fairly sophisticated signal coding and processing to eliminate ground clutter interference yet not lose targets trying to fly in under ground radar limits.

Some modern system antennas are using phased array techniques to be able to scan the beam rapidly without waiting for a massive antenna to move mechanically. This is especially important for multiple target tracking such as in naval operations.

The FPS-85 satellite and space junk tracker in Florida is a massive 12-story high phased array station which identifies and keeps track of the hundreds of items of orbiting hardware.

Military air operations need considerable sophistication for control and coordination. In addition they need transportability. A typical system built by Gilfillan is the TPS-48 which combines a height finder and search radar for use in landing operations. The Marine Corps has similar requirements. It is fully air-transportable.

Carrier landing systems require more precision and usually use higher frequencies for better resolution. SPN-31 at 34—36 GHz is typical. A variety of search and homing systems are used for fleet air operations.

RADAR FREQUENCY ALLOCATIONS

Band Name	Frequency Range (MHz)	Typical System
L-Band	1300—1350	Air Route Surveillance Radar (ARSR) Airborne Warning & Control (AWACS)
	1500	Rendezvous Radar, Apollo
S-Band	2700—2900	Airport Surveillance Radar (ASR)
	3100—3700	Navy Shipboard Search Radar
C-Band (HP G-Band J-Band)	4200—4400 5400—5900	Radar Altimeter Missile Fire Control Navy TARTAR, Hawk
X-Band	8.4—9.5	Fire Control Radars
	8.75	Battlefield Personnel Surveillance (PPS-9)
	10.555	Police Speed Radar
K _u -Band (HP P-Band)	13.3	Airborne Doppler Navigator (APN-200)
	15.4—15.7	Microwave Carrier Landing System (SPN-41)
	15.7—17.7	Airborne Fire Control Missile Guidance
	16.0—16.5	Collision Avoidance System Battlefield Surveillance Radar (PPS-5)
K-Band	24.25—25.25 25.25—27.5	Taxi Radars (FPN-31) 24 GHz
K _a -Band (HP R-Band)	33—36 GHz	Mapping Radars
mm	90—100 GHz	Terminal Guidance Radars

TRACKING & GUIDANCE RADARS

“Fire control” deals with systems which track targets and aim guns or missiles. Again they occur in a variety of applications with only some typical examples shown. A critical design parameter is the ability to handle and process multiple targets and sort the prime threat.

Each weapon system has its own envelope of performance, i.e. air to air, and this usually determines the frequency range and signal pulse parameters. Thus, airborne is usually X-band for antenna size considerations while Navy fire control is typically C-band (5.4—5.9 GHz). Some systems are K_u band (HP: P-band) at 15.4—17.7 GHz.

Coupled in with the fire control is often a command link to the opposing aircraft operating in the 1000 MHz band which is called Identification, Friend or Foe (IFF). If the target responds with a predetermined code, fire is withheld.

Modern superiority fighters such as the F-15 use multi-function radars. Thus, it performs different functions at different parts of the mission profile: fire control, mapping/navigation, terrain following/avoidance, and weather.

Once launched, many missiles use radar guidance. The missile homing system from the F-14 is one example. Other examples are the SHRIKE or Standard ARM (Anti-Radiation Missile) which home in on radar radiation. The new cruise missile technology uses 90—100 GHz millimeter wave radars for terminal guidance and will search the terrain for a digital map which matches a pre-stored pattern of the desired target area.

A variety of other military systems exist. Mortar fire control radars detect incoming fire, compute backwards from the trajectory and plot return fire. Battlefield situation radars can track and distinguish vehicles and personnel movements. Both of these are highly portable.

Police radar is a simple application of a CW doppler technique. Mixing a 10.5 GHz output signal with a doppler-shifted return from a moving vehicle gives an audio beat. This is metered and frozen on a digital display. The whole process only takes about 0.1 second so the so-called “Fuzz Buster” counter-measure boxes don’t do much good. Modern units operate in both X-band and K-band.

Commercial aircraft may carry multi-function navigation radar. These usually operate in X-band 8.4—9.5 GHz (for size and weight), and can easily detect formations of severe weather which must be avoided. For a time, doppler radar navigation systems were used to detect movement of the plane over ground water. However, inertial navigation technology has largely supplanted these 13 GHz systems.

OTHER RADAR SYSTEMS

Numerous other systems abound. Specially-configured ground radars look for severe weather. These usually operate in C-band to be more sensitive to weather. Mapping radars operating in millimeter waves (34—36 GHz) and using “side-looking” processing techniques for increased resolution provide land mapping capabilities with displays giving information supplemental to optical and infrared photography.

A variety of scientific radars are used for radio-astronomy and universe-mapping. Typical is the Aricebo (Puerto Rico) dish about 1 mile diameter with a moveable feed-horn. Or the Stanford University 150 foot dish behind Palo Alto.

Many aircraft use radar altimeters. These systems operate from 4200 to 4400 MHz on an FM doppler principle and give superior resolution and accuracy of a few feet.

RADAR PRINCIPLES SURVEILLANCE RADARS

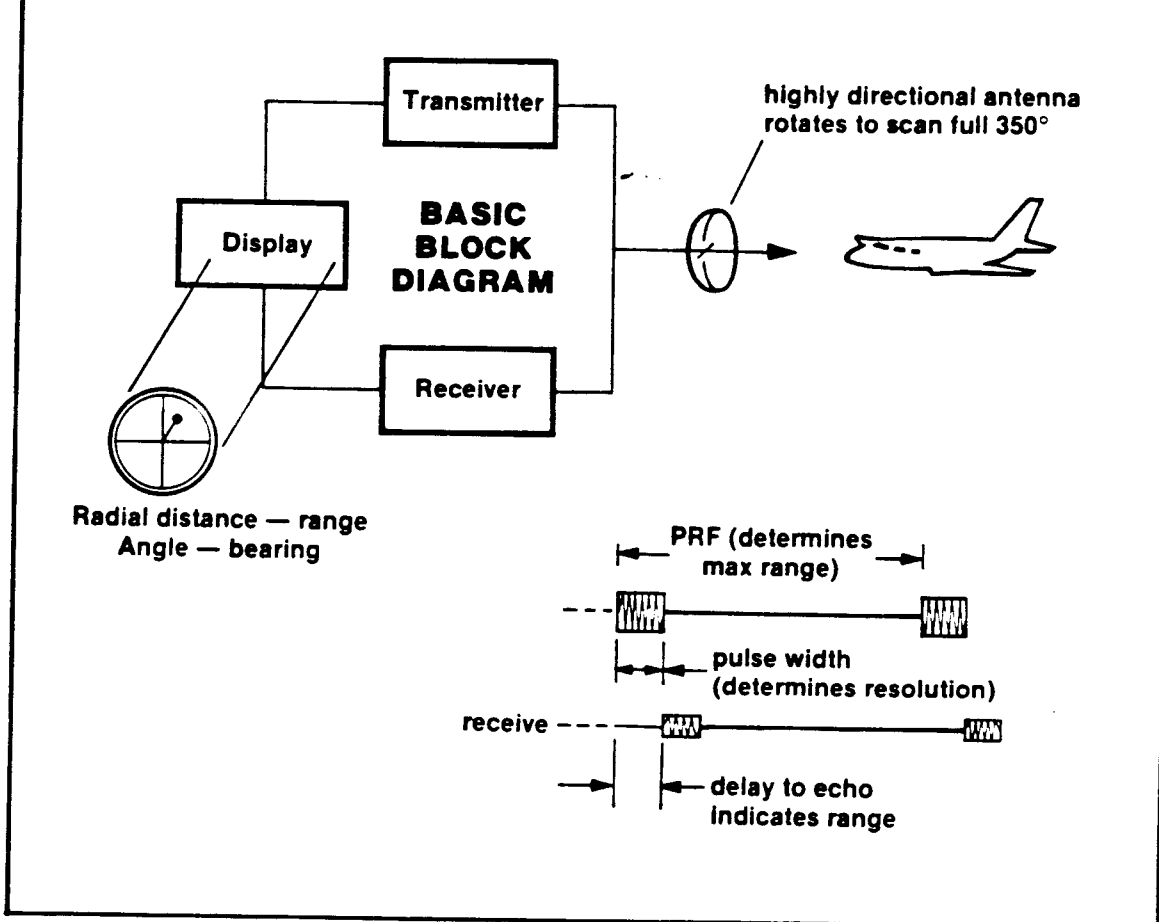

This simplified block diagram will illustrate the basic principles common to all radars. A radar transmitter generally emits a pulse modulated MW signal with periods between pulses that are used to listen for reflections from targets within the field of view of the radar. 1000:1 duty cycles are typical. The directional antenna defines the spatial resolution of the radar and it rotates to look at all sectors that are of interest. If we are scanning the horizon, it will rotate 360°. If we are looking overhead, it will scan some spherical sector. At each point in this scan, it will transmit a pulse and wait for any echoes. The delay to the echo indicates the range to the target; the direction that the antenna is pointing indicates the bearing to the target, more or less. Antenna side-lobes and back lobes have some ability to transmit and receive and thus can respond to targets well off bore sight.

RADAR PRINCIPLES

RANGE RESOLUTION

$$\frac{\text{Resolution (ft)}}{500} \geq \text{Pulse width } (\mu\text{s})$$

A 1 μs pulse gives range resolution of 500 feet

RANGE vs REPETITION FREQUENCY

$$\text{Repetition frequency (Hz)} < \frac{90000}{\text{Range (miles)}}$$

For 200 miles range, repetition rate must be less than 450 Hz

Two things that are worth remembering concerning radars are how the repetition frequency of the radar and the width of the transmitted pulse effect the operating characteristics. Pulse width determines how closely two targets can be spaced and still produce two separately distinguishable echoes; the narrower the pulse, the closer the two targets can be. As a rule of thumb, a one microsecond pulse will resolve targets that are 500 feet apart. If the targets are closer than 500 feet, the echo from the second target will start to reach the receiver before the echo from the first target has finished, thereby superimposing the two echoes and not resolving them.

Repetition rate of the radar affects the distance to the farthest target of interest. If a target that is a long way away produces an echo that reaches the radar just before the next transmit pulse occurs, then no ambiguity results. But if on the other hand, an echo reaches a receiver after a subsequent transmit pulse, then the radar can't distinguish the far-away echo from one nearby. A rule of thumb worth remembering here is that the repetition frequency should not exceed 90 kHz divided by the longest usable range in miles. (90 kHz derives from the fact that its period is 11 μs and a round-trip propagation time for a mile is 10 μs). So if you are using a radar that is to operate over, let's say a 100 mile range, its repetition frequency should be 900 Hz or lower. As you would imagine, you would like the repetition frequency to be as high as possible because that puts out more average power, but you must adhere to this maximum repetition frequency dictated by range.

RADAR PRINCIPLES TRACKING RADARS

CONICAL SCAN

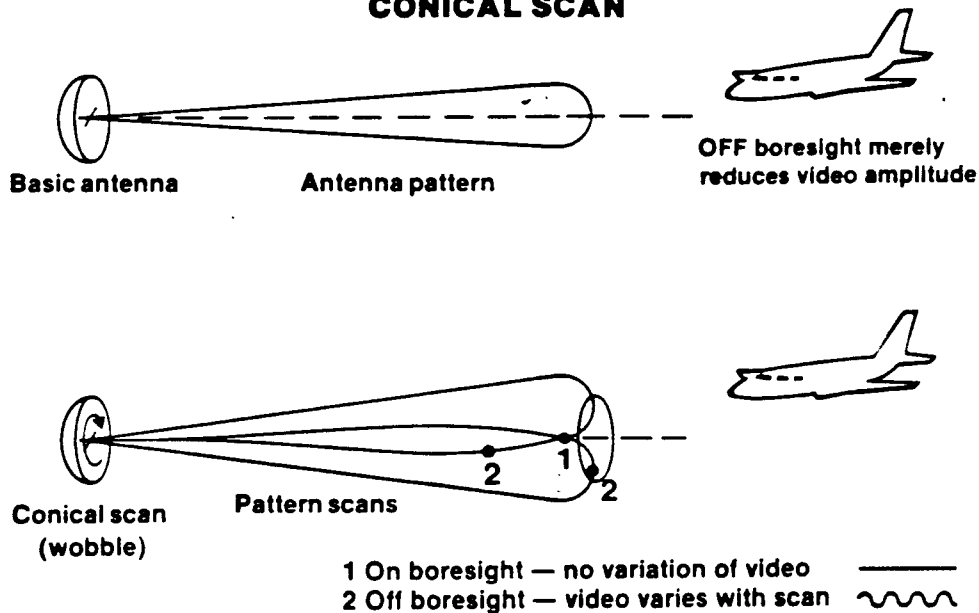

Tracking radars differ from surveillance radars in that the antenna seems to achieve bore sight after it's acquired a target. The antenna is directed at the target and slaved to it. The slaving is accomplished by a small conical scan to give an error signal indicating when the radar is not pointed directly at the target. You can see in the lower diagram that a conical scan results in no variation in the amplitude of the echo if the antenna is pointed directly at the target. If the antenna is off "boresight", then the size of the echo will change during conical scan in such a way as to indicate the directional error, and servos bring the dish back to boresight.

RADAR PRINCIPLES

MOVING TARGET INDICATOR

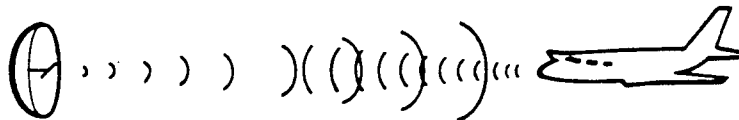

Target coming toward radar has echo at slightly higher frequency (doppler effect).

Another refinement of a radar system is designed to give velocity information as well as range and bearing. These kinds of radars are often called moving target indicators (MTI). They operate similarly to the tracking radars that we talked about earlier with added capability to determine the frequency of the echo received from the target. Because of a phenomenon known as doppler shift, the echo will be a slightly different frequency than the transmit signal if the target is either approaching or going away from the radar system. If the target is approaching, the echo will be at a slightly higher frequency than transmitted (less time); if receding, at slightly lower (more time). The radar can measure the difference frequency between the echo and the transmit pulse and then determine not only the position of the target but its speed, whether closing or receding from the radar. This function is important for evaluating threats.

RADAR PRINCIPLES TRACKING RADARS

MONOPULSE

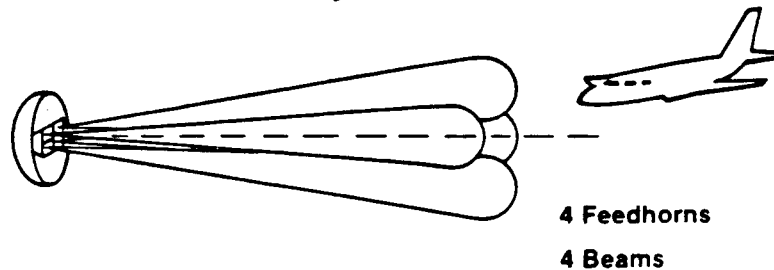

Return signal phase front is processed with sum and difference hybrids to compute angle off boresight from single pulse

A form of tracking radar that does not need to use conical scan because it simultaneously transmits four well defined beams is called a monopulse radar. Monopulse means that it can, with a single transmit pulse and these four beams, determine the angle of the target with respect to boresight. The antenna still slaves onto the target. The advantage of monopulse is its significant resistance to jamming from the target. However, it is quite a lot more sophisticated since transmitter & receiver LO must be coherent. The use of 3 or 4 channels allows the angle of echo return to be computed from a measurement of the electrical phase differences of the signal in each channel.

RADAR PRINCIPLES

CHIRP RADAR

CONVENTIONAL

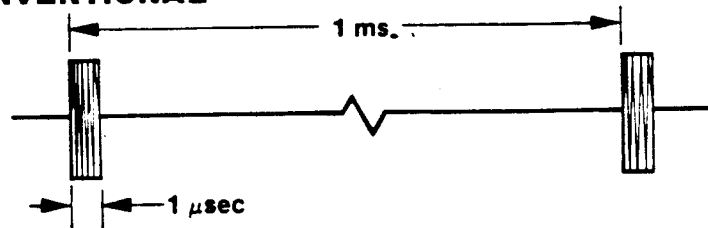

CHIRP

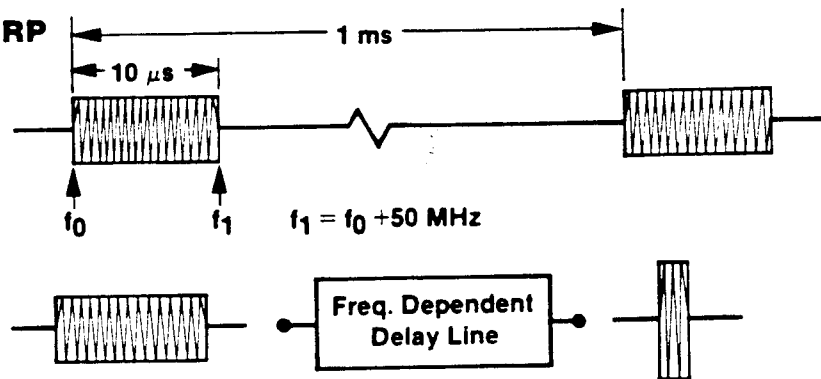

A very sophisticated form of radar uses the combination of pulse modulation of the envelope and frequency modulation of the carrier. These radars are called "chirp" radars. The motivation for a chirp radar is to transmit a fairly wide pulse and still have very good resolution between closely spaced targets. As the pulse width becomes more narrow, the receiver band width must become wider and the usable range of the radar is reduced unless the transmit power is increased proportionally. That's an expensive thing to do, so chirp radars reduce amount of peak power by widening the pulse but recover the range information by signal processing the echo. Instead of a one microsecond pulse, a chirp radar might work with a ten microsecond pulse that slews the carrier frequency during the pulse by as much as 50 MHz.

The receiver side of a chirp radar then must take the echo and process it through a circuit that has differing delay versus carrier frequency. It will have more delay at the lower frequency and less delay at the higher frequency so that the beginning of the pulse is delayed more than the end of the pulse. This effectively creates a narrow pulse so that we can resolve the two closely spaced targets. An equally important advantage of chirp is that the transmitted frequency is broader or "spread spectrum" making the radar more difficult to jam. "Comparison" factors of 1000:1 (30 dB) are typical.

RADAR MEASUREMENT CONSIDERATIONS

- **Mostly pulsed RF simulation & measurement**
- **Typical requirement**
 - 60—80 dB on-off ratio**
 - 0.1 μ s risetime**
 - 1.0 μ s pulse width**
 - 1.0 kHz pulse repetition frequency**
- **High resolution radar**
 - 10—50 nanosecond risetime**
 - 0.2 μ s pulse width**
 - 10—100 kHz pulse repetition frequency**
- **Sensitivity**
- **Image rejection**
- **Spurious responses**
- **Sensitivity time control (STC)**
- **Noise figure**
- **Transmitter power**
- **Transmitter spectral characteristics**

Radar receiver measurements are those of a superheterodyne radio handling wideband pulsed spectra. Signal generators require 60—80 dB on-off-ratio pulses with low leakage for sensitivity or AGC tests. High levels in the 1 and 10 mW are needed for spurious and image rejection tests. Traditional tests on noise figure are usually done.

Most test pulse signals are synchronized with the system clock so they truly simulate a target. Tests on CHIRP or radars with fancy ECCM or MTI doppler are quite a lot more complex. Frequency agility or CHIRP waveforms are difficult to duplicate and are often done with specialized test fixtures. Some of the new synthesized signal generators are getting stable enough to perform these tests (1:10⁻¹⁰). A very sophisticated form of radar uses the combination of pulse modulation of the envelope and frequency modulation of the carrier.

Transmitter tests involve power, frequency and spectral characterizations. Spectrum analyzers are important along with traditional counters and power meters.

HP dominates the field of radar testing, mostly because high performance is the primary objective and cost secondary.

NAVIGATION SYSTEMS

SYSTEM	BAND	APPLICATION
VOR (VHF Omni Range)	VHF (108—118 MHz)	En-route Positioning
DME (Distance Measuring Equipment)	UHF (960—1215 MHz)	En-route Positioning
ATC Transponder (Air Traffic Control)	UHF (~ 1 GHz)	Aircraft Identification
ILS (Instrument Landing System)	VHF Localizer: 108—112 MHz Glide Slope: 330 MHz Outer Marker: 75 MHz Inner Marker: 75 MHz	Airport Approach
TACAN (Tactical Air Navigation System)	UHF (960—1215 MHz)	Military Version of VOR/DME
IFF (Identification Friend or Foe)	UHF (~ 1 GHz)	Target Identification
MLS (Microwave Landing System)	C-BAND (~ 5 GHz) (~ 15 GHz)	Airport Approach & Zero-Zero Landing
GPS/NAVSTAR (Global Positioning System)	UHF 1.5 GHz	En-route Positioning

Let's now look at some navigation systems using the RF & MW spectrum. VOR is used for aircraft positioning en-route. It involves a network of transmitters that a pilot can tune to and determine his bearing to the station. By triangulation using two stations, the pilot can know his exact position. DME stands for distance measuring equipment that uses a separate UHF transmitter to determine range. The ranging works when the aircraft interrogates the DME ground transmitter and measures the delay time between interrogation and the received response.

Air traffic control transponders are contained in commercial airplanes so that ground based radars can interrogate the airplane and automatically determine its identity and altitude. The instrument landing systems currently in use operate at VHF and consist of transmit patterns that allow an airplane to fly in a glide slope and with little or no visibility and make an accurate approach to a runway. Currently a new landing system operating in MW frequencies has been adopted called the Microwave Landing System (MLS).

TACAN is an acronym for a tactical air navigation system similar to the VOR and DME. IFF is also a transponder system to identify whether an airplane is friend or foe, and which withholds missile firing if the "target" is friendly.

MICROWAVE LANDING SYSTEM

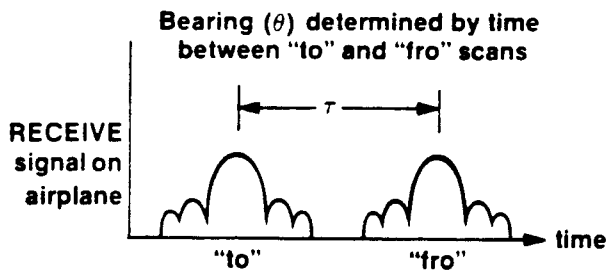
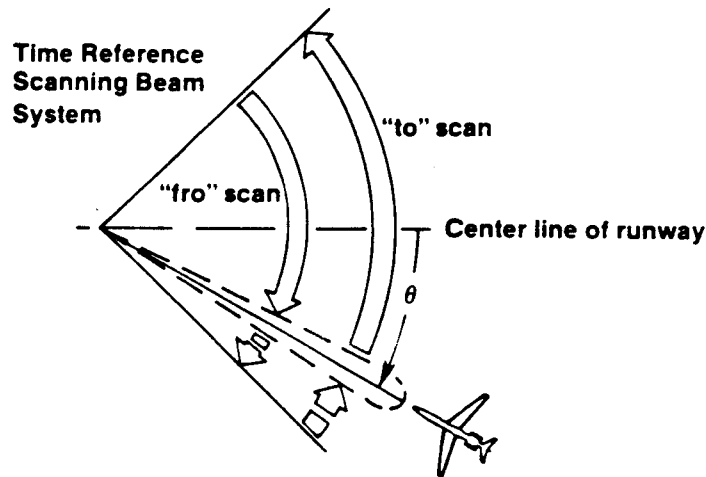

τ (millisec): 13.8 8.8 0
 θ (degrees): 40 0 -40

Let's take a look at how one of these navigation systems (MLS) operates. It's referred to as a time reference scanning beam system (TRSBS). This system uses an electronically steered antenna array that transmits a well defined beam over a sector of 40° either side of the runway. It scans that sector in a precisely timed manner so that the difference in time between successive scans tells the receiver on board the airplane what its bearing is with respect to the center line of the runway.

You can see from this diagram that the plane will intercept a signal on a "to" scan and sometime later intercept a second signal on the "fro" scan. The time difference between the "to" and "fro" indicates the position of the airplane in respect to the center line of the runway. A time delay of 6.8 milliseconds indicates that he's right down the center. A second scanning beam determines elevation, so the pilot knows both angles of approach to the runway. This system is much more flexible and accurate than the VHF system that has served for years. Motivation to upgrade comes from the large increase in traffic at major airports. The military will also use compatible versions of the MLS. In fact, some high accuracy models will permit hands off landings.

ELECTRONIC WARFARE

ACTIVITY	PURPOSE	EQUIPMENT
Intelligence Gathering	Radar Signatures Eavesdropping	Surveillance RCVR
Countermeasures	Threat Detection Confusion Deception	Warning RCVR Jammer
Counter Countermeasures	Defeat ECM	Sophisticated Radar Comm System

Electronic warfare applications for the RF & MW spectrum are divided into three commonly accepted subcategories. *Intelligence gathering* involves surveillance equipment either to determine how the enemy's defensive systems operate or to decode and eavesdrop on the information that is being carried. The eavesdropping application involves RF spectrum primarily and single channel voice type modulation. Radar intelligence involves receivers similar to a spectrum analyzer to determine the carrier frequency, pulse width, and pulse repetition frequency of the ground and air based radars that are being used by the enemy.

Countermeasures take advantage of the information that has been gathered by the radar intelligence to construct warning receivers that are programmed to recognize certain classes of radar threat signatures and to trigger a transmitter whose purpose is to confuse that radar.

The third subcategory is Counter-CounterMeasures (ECCM) which is the action taken by radar designers to avoid being jammed. In radar and communications systems this may involve frequency hopping of the transmitter and/or fancier modulation techniques to spread the transmitted spectrum and thus "burn through" the jamming.

INTELLIGENCE GATHERING

ELECTRONIC SUPPORT MEASURES (ESM)

Multiband receivers to search, interpret, locate, record and analyze threat signals

- **Signal Intelligence (SIGINT)**
- **Communications Intelligence (COMINT)**
- **Electronic Intelligence (ELINT)**

Electronic Support Measures (ESM) encompasses a very wide variety of receivers and operates across the entire microwave spectrum. This is usually a stack of sophisticated radios which electrically scan extremely wide frequency bands looking for communications or threat signals. Signal intelligence (SIGINT) is generally understood to cover all transmitted signal information and thus includes COMINT & ELINT.

COMINT receivers look for Communications Intelligence in the spoken word or coded messages from hundreds and thousands of radios. Electronic Intelligence (ELINT) looks for threat signal characteristics of particular radars so you can recognize it later. Such characteristics as frequency, pulse rate, pulse width, conical scan data and other subtle effects like antenna pattern lobes.

ELECTRONIC WARFARE SYSTEMS

Radar Warning Receiver

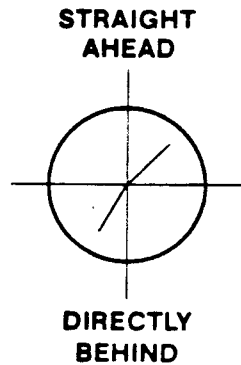

Shows pilot bearing of radar transmitter that matches signature of known enemy equipment. Here we see threats at 1:00 and 7:00 o'clock.

RWR consists of broadband receiver with post detection waveform analysis. Generally uses lots of digital signal processing to determine radar's carrier freq, pulse width, and pulse repetition freq and to look up whether it's friend or foe.

A radar warning receiver (RWR) shows when a radar threat signal is being received at the airplane with sufficient signal strength to produce an echo that would make him visible to that radar system. It will ignore radars that are known to be friendly but present on the display an indication of the bearing of a radar transmitter if the signal is known to be an enemy. Once the pilot knows that he's being illuminated by a threat radar he can turn on his jamming transmitter. Modern displays provide priority alpha numeric codes to prompt a pilot to the highest threat.

Receivers are fast-sweep super-heterodyne with various schemes used to eliminate images and spurious signals. Some early warning sets use ultra-broadband video detection so that probability of intercept is improved. Often the video sets use arrays of antennas which watch each quadrant of the sky to display direction and type of surface-to-air missile threat.

With some battle scenarios predicting hundreds of threat emitters, considerable design effort goes to signal processing, sorting, identification, prioritizing and display. Microprocessors are becoming ideal ways to store known threat signal characteristics for later use — even to the point of loading of particular mission profiles to allow recall of the appropriate data just before take-off.

JAMMER

Adaptive Transmitter Programmed
to Confuse Radar that RWR has Detected

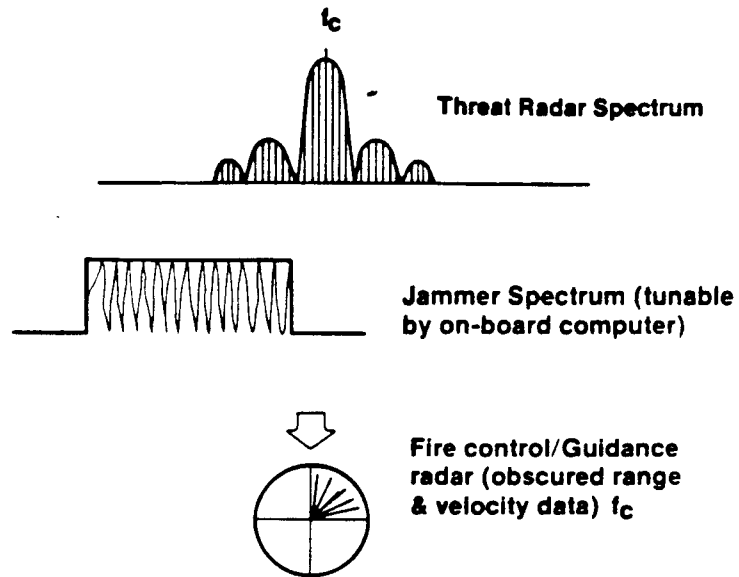

Jamming can be noise or deception jamming. If you can get enough noise into the other receiver, it might "break lock". Or you can retransmit slightly modified versions of the threat signal to make it look like your aircraft is moving way from where it really is. ECM transmitters are multi-band dual-mode (pulse and CW) moderate power TWT (500-1000 watts), often mounted in external pods.

All this may seem like a game, but it is very serious business. It has been repeatedly demonstrated that \$500K of EW equipment on a \$20 million aircraft improves its survivability ratio in battle by a margin that far outweighs the complexity and cost. Do the same analysis for a Navy carrier and EW becomes crucial.

ELECTRONIC WARFARE MEASUREMENT CONSIDERATIONS

- **RECEIVER TESTS**

- Sensitivity**
- Signal/Noise Ratios**
- Noise Figure**
- Flatness**
- Image Rejection**
- Bandwidths**
- Frequency Accuracy**
- Intermodulation**
- Multiple Emitter Overloads**
- Burnout Resistance Tests**
- Automatic Signal Identification Tests**
- Pulse Response Tests**

- **TRANSMITTER TESTS**

- Frequency**
- Power**
- Pulse Characteristics**
- Spectrum Characteristics**

Microwave measurements required for EW equipment are fairly traditional. Since the EW systems are working with communications, radar, and navigation signals, both modulated and pulsed signals must be simulated. The bulk of the activity so far has been up to 18 GHz but now receivers are being built to 40 GHz.

Since many of these receivers must operate in dense signal environments, multiple signal overload tests often require signal simulations with multiple sources. This can sometimes be done with fast switched synthesizers and even pulse-to-pulse switching.

Another strong trend is the need to test so many parameters over such wide bands that programmable testing becomes crucial. SPD's 8672A, 8672S, 8673B/C/D Synthesizer, 11720A Pulser, and 436A Power Meter are very useful for mini-system configuration.

Transmitter system testing uses many of the same considerations. Power output vs. frequency, spectral characteristics, and pulse characteristics must all be measured.

ECCM SYSTEMS
RADARS DESIGNED TO
"BURN THROUGH" JAMMING:

FREQUENCY HOPPING
PULSE RATE JITTERING
CHIRP
PHASE MODULATION
MONOPULSE

As new fire control radar is designed and put into place, countermeasures equipment is designed by the other side to neutralize its effect. That leads to the next phase — Electronic Counter-CounterMeasures (ECCM). Electronic Counter-CounterMeasures is that branch of EW that pits radar designers against jamming. This results in far more sophisticated radars that can cope with jamming. They do this by one of three techniques:

1. They hop the carrier frequency. If the carrier frequency can be shifted faster than the pilot's radar warning system and jammer can follow, then the radar will see through the countermeasure system.
2. If the pulse repetition rate of the radar's transmitter can be changed so that the echoes are received in a random pattern known to the receiver, proper signal processing can enhance the desired echo in the presence of noise and again allow the radar to see through the noise.
3. Chirp and phase modulation are similar ways to spread the spectrum so that although it's lower in energy density than the jamming noise signal, it's correlated in a way that the receiver knows about and hence is able to pull out of broadband noise jamming signals.

Other operational techniques are being used such as "Bi-Static" radars. These use a single aircraft to illuminate targets. The returns are picked up by passive receivers in the tactical aircraft which are harder to jam because you don't know their location for directional jamming.

Monopulse helps defeat jamming because it only requires a few pulses to find the target — before a jammer can react. The radar can then be made to "blink" (turn on and off) to "lose" the jammer.

OTHER MICROWAVE SYSTEMS

**Space Telemetry
Test Range Telemetry
Antenna Testing Ranges
MW Ovens & Industrial Drying
Particle Accelerators
Radio Astronomy
Metrology Labs**

The highly successful Apollo moon programs used an integrated S-band channel to relay everything from TV pictures to astronauts' heartbeat. All data was digitized, including the TV channel. Deep space research satellites use very sophisticated telemetry.

Telemetry is widely used in test and evaluation of air frames, weapons, missiles and space research. Hundreds of channels of vibration, stress, pressure and electrical parameters are monitored, multiplexed and transmitted to ground stations over the 1435-1535 MHz band. FM-FM formats are common but digital modulations are emerging.

In the test and evaluation phases of new weapons systems, major efforts go into full scale range tests. Missile ranges like White Sands in New Mexico and Elgin AFB in Florida bristle with tracking radars and positioning systems to determine whether missiles perform properly.

Elaborate bomb scoring and tactical maneuver positioning systems are used at ranges like Nellis AFB, Nevada or gunnery ranges at Fallon, Nevada to precisely determine and plot positions of friend/foe mock air battles. Most of these systems use microwave pulsed signals and time-of-arrival triangulation techniques to provide computerized operations data.

Every radiating microwave system uses an antenna, ranging from a simple stub to highly complex phased arrays. Virtually every one goes through comprehensive antenna range tests for pattern, side lobes, sensitivity and gain and bandwidth. Most of these ranges use computerized synthesized signal sources for the test signal and automated pedestals for sweeping the test antenna at sequenced azimuths and elevations.

Microwave ovens are fast becoming one of the only true consumer applications of microwaves. These operate at 2450 MHz. A surprisingly large amount of industrial process heating is done by microwaves. It is particularly valuable where precise control is needed on moisture content, such as plywood glue drying or potato chip processing. In fact, it is ideal for such applications precisely because its heating effect comes from transferring heat to water molecules, and the heating stops when the water goes away.

Microwave frequencies are used in particle accelerators such as the Stanford Linear Accelerator. 250 S-band klystrons with 20 MW peak power are spaced each 40 feet and when properly phased into a periodic cavity structure have yielded new atomic insights and at least 1 Nobel Prize.

A variety of scientific radars are used for radio-astronomy and universe-mapping. Typical is the Aricebo (Puerto Rico) dish about one-half mile diameter with a moveable feed-horn. Or the Stanford University 150 foot dish behind Palo Alto.

Metrology labs for calibration and traceability of company standards are a large application for HP gear, namely because of the precision required. High stability sources, power meters, noise standards, attenuation and impedance measurements all are required to assure that design, manufacturing, and QA facility test equipment is turning out products which meet specification.

